



9615 SW Allen, Suite 103
 Beaverton, OR 97005
 Phone: (503) 643-4899
 800-275-4899
 Fax: (503) 372-1266
 Website: www.cui.com

Specifications

1	Part No.	GF0776M			
2	Nominal Size	77 mm.	3"	inch	
3	Impedance	8Ω ± 15%	at	800 Hz.	1 V.
4	Resonance	360 Hz.±	72 Hz.	FO Hz.	1 V.
5	S.P. Level	91 dB±	3 dB	1 w. 50 cm. average at	
6	Response	fo Hz.~	11K Hz.	MAX 10dB	1K, 1.4K, 1.7K, 2K Hz.
7	Crossover Freq.	Hz.	Hz.	dB/OCT	Net work
8	Input Power	Nominal Input	1 w.	Handling Capacity	2 w.
9	Operation	Must be normal at program source			1 w.
10	Buzz, Rattle, etc.	Must be normal at sine wave			2.82 v.
11	Flux Density	Gauss ± 10%			
12	Total Flux	Max well min			
13	Magnet	Size	32 x 18 x 6 mm	gr	oz
14	Total Weight	gr oz			
15	Load Test	After test meet item 9 and 10	White noise	1 W.	24 Hours
16	Distortion	% MAX		Hz	W.
17	Heat Test	After test meet item 9 and 10	60±2 ±°C	20-50 %R.H.	24 Hours
18	Humidity Test	After test meet item 9 and 10	40±2 ±°C	90-95 %R.H.	24 Hours

PART NO.	GF0776M	UNITS:	mm
DRAWN BY:		PAGE NO:	1 of 2

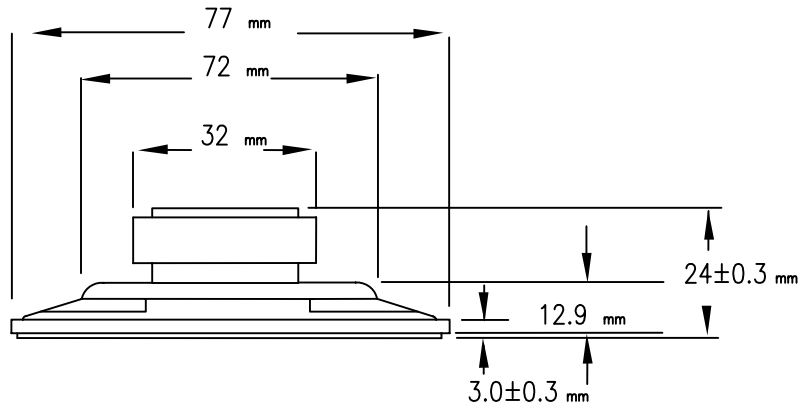
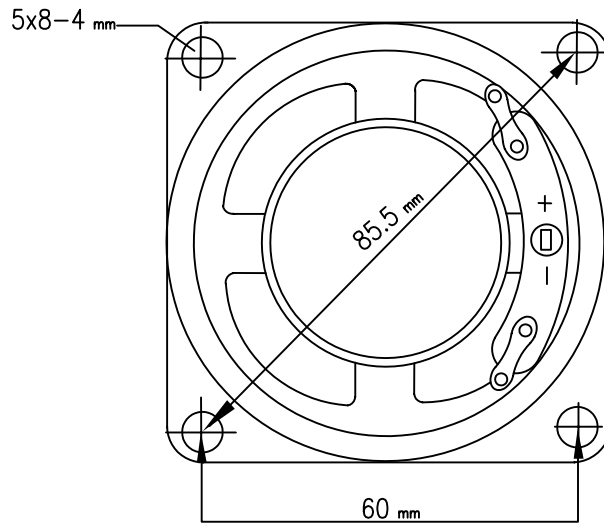

9615 SW Allen, Suite 103
 Beaverton, OR 97005
 Phone: (503) 643-4899
 800-275-4899
 Fax: (503) 372-1266
 Website: www.cui.com

TITLE:

PART NO.

GF0776M

UNITS:

mm

DRAWN BY:

Page No.

2 of 2